

The following is the recommended configuration for tabletop assembly. You can use a different setup at your workshop.

STEP #1 Start with a 24" x 48" piece of 3/4" Plywood. This will be your tabletop.

STEP #2 Position the outer center tracks as shown below 13" from the ends. Mark the positions for the 6 pilot holes which you will need to drill. Attach these two tracks using the included Screws.

Step #3 Measure a 6" square from each corner of the table top. (as shown) Drill a hole in each of the 4 markings using a 5/16" drill. Attach the 4 corner tracks using the provided washer, Nylon Lock Nut, and T- bolt. Tighten them firmly, but allow for the rotation of tracks.

Step #4 The remaining center tracks (shaded gray below), can be spaced as shown, or at even intervals and attached with the included screws.

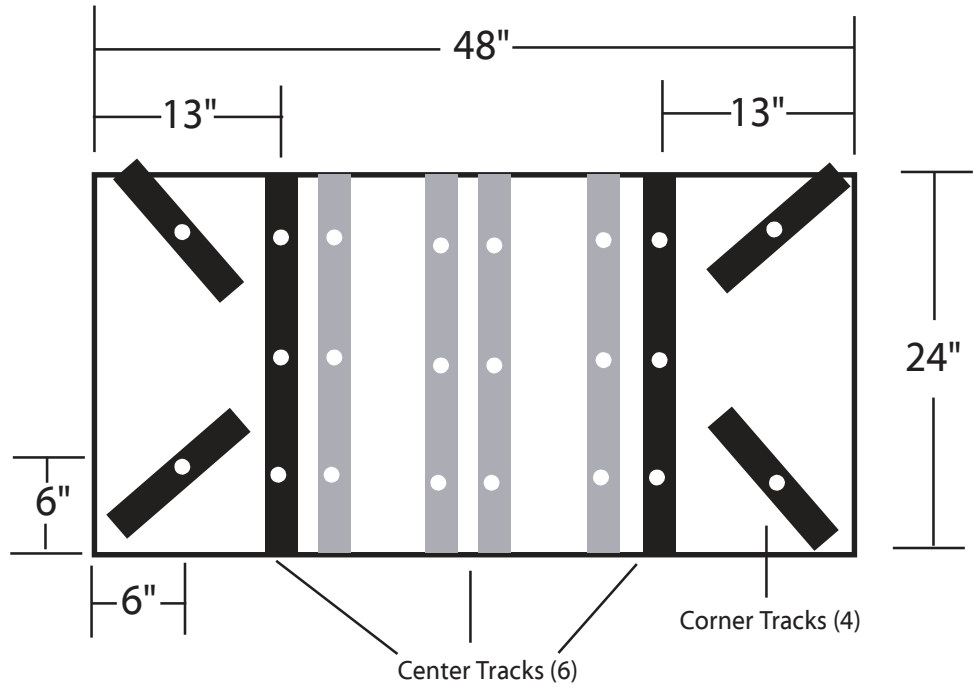

Nylon Lock Nut, Washer & T-Bolt
(used with corner tracks)

STEP #5 Screw 24" long pieces of 1"x4" wood into the rails. Use 5 screws per rail for proper support Positioned as shown below.

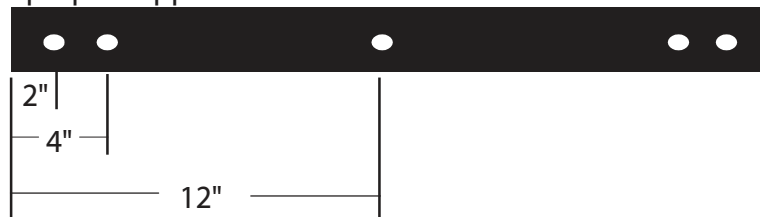

Screws for attaching your wood (1" x 3") to the rails